

## Fill Between 2 Ends

This command provides a simple and effective way for the user to join two Items of duct, pipe or electrical containment that are distances apart. It allows the selection of the ends to be joined, then presents the user with possible options for joining the Items.

The **Fill Between 2 Ends** command uses the products available from the currently selected service. These Items should be certified to prevent the user from being prompted for sizes etc. If the Items are not certified the operator must click OK to each prompting dialogue window.

**Note:** When using Fill the products are automatically sourced in the order they are displayed. If there are two bend Items, i.e. Radius and Mitred, the first in the list will be used. There is the option to any exclude any of the **Service Items** from the Fill routine via the **Exclude from Fill** option.

### Procedure

The **Fill Between 2 Ends** command is accessed by one of the following methods:

From the toolbar **Select**  **Fill2Ends**  
At the **command line** enter **fill2ends**  
**Shift Right Click** menu **CadDuct Solids BSS > Fill Between 2 Ends**

### Example: Single Bend

In this example, the ductwork fittings are positioned on the drawing at approximately 90° to each other on the XY Plane: There is no difference in the Z height between the connector nodes and the duct sizes are the same.

**Note:** Other angles are supported, but this depends on the Service selected and the available products.

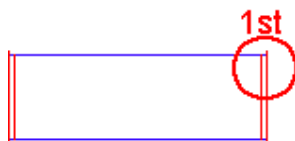
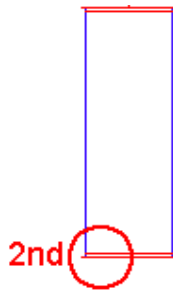

Click the  **Fill Between 2 Ends** icon the user is presented with the **Fill Between 2 Ends Options** window – in this case the **Single Bend** option has been selected although the user should select the option that best suits his requirements.

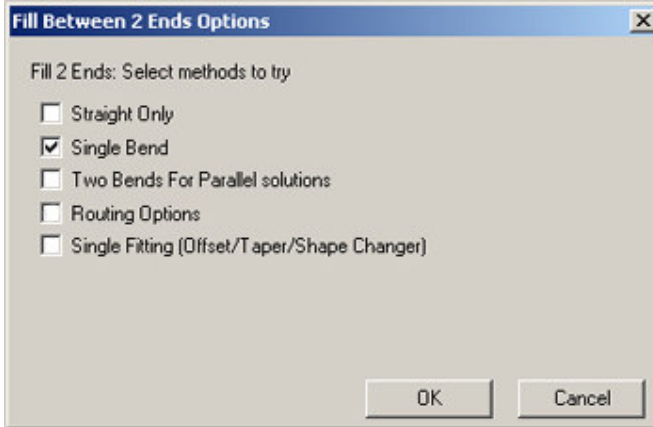

Click on the connector end of the **first Item** to be joined

Click on the connector end of the **second Item** to be joined

As the image below shows, the user is presented with command line options. Typing **N** followed by the **Enter** key scrolls through the possible results, displaying each in real time.

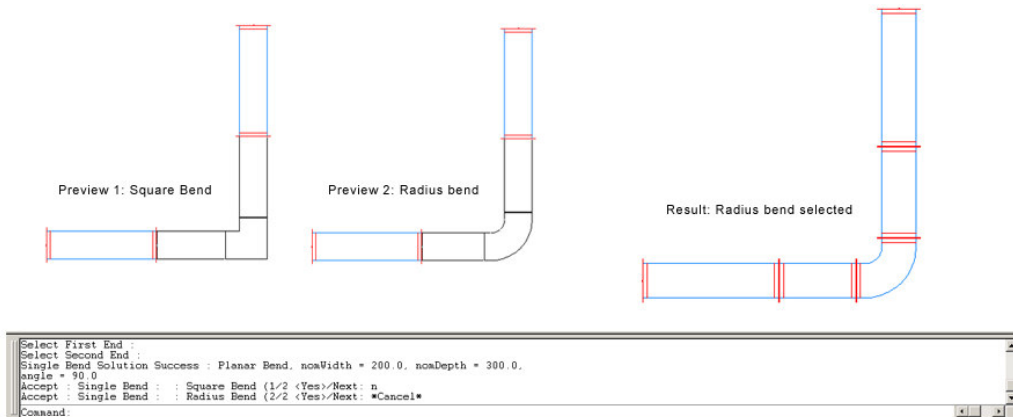

After **selecting** one of the options the two duct Items should now be joined.

Although the connector size is determined by the selected connector ends, additional sizes i.e. the length of the bend extensions and the length of the small pieces of straight duct are determined by the **Stretch Options** in the **Main Database**.

For additional information relating to these options see the tutorial covering **Stretching**.

### Example: Two Bends For Parallel Solutions

In this example, the ductwork fittings are not on the same level in the XY plane but they have the same Z-axis value. The duct sizes are the same.



Click the  **Fill Between 2 Ends** icon

the user is presented with the **Fill Between 2 Ends Options** window – this time the **Two Bends For Parallel solutions** option has been selected.

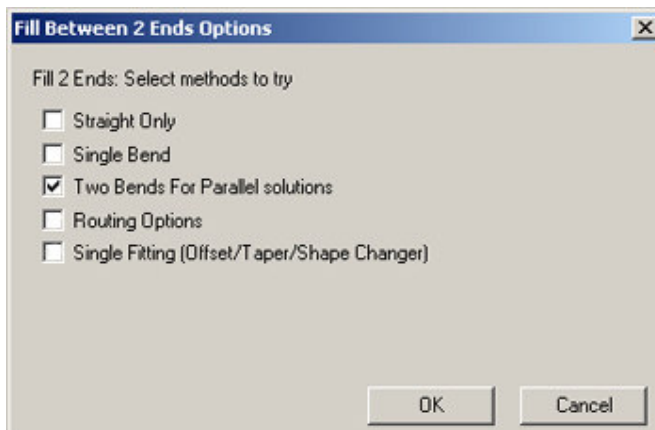

**Click** on the connector end of the **first Item** to be joined

**Click** on the connector end of the **second Item** to be joined

again, the command line lists the possible options.

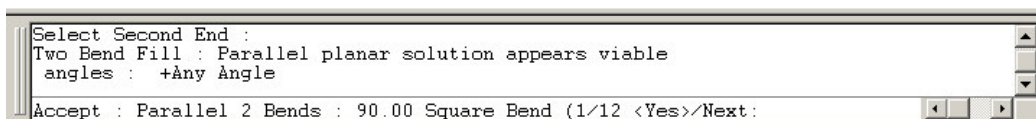

**Note:** The above options are automatically filtered by CAD-Duct Solids and impossible combinations are removed. For this reason, the available options may vary each time the command is used, depending on the scenario.

Type **N** followed by the **Enter** key to scroll through the available options. Each option is outlined within model space in real time as a preview of the resulting selection.

Making the most of CAD-Duct Solids

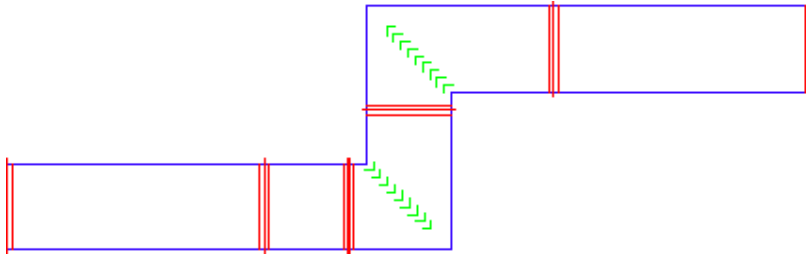

**<1> 90.0**

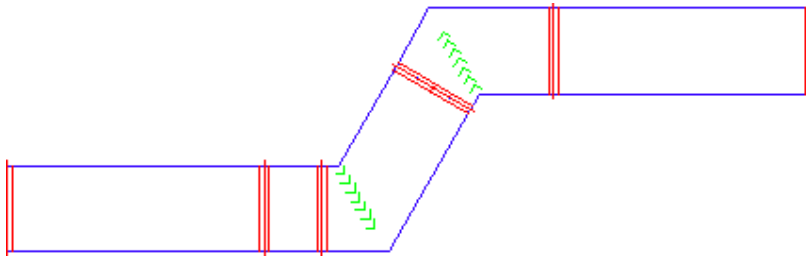

**<2> 60.0**

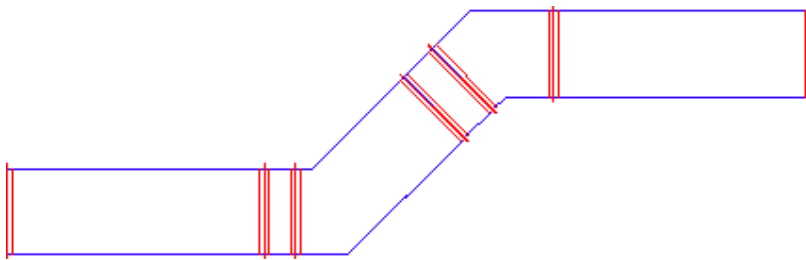

**<3> 45.0**

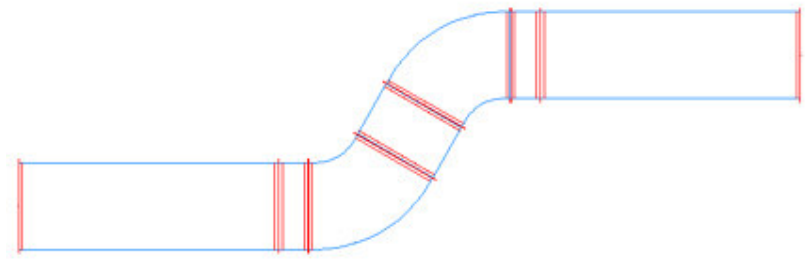

**<4> 60 Radius Bend**

## Example: Routing Options

In this example, the drawn fittings are not on the same level in the XY plane and also have different Z axis values. The connector sizes are the same.

Click the  **Fill Between 2 Ends** icon

the user is presented with the **Fill Between 2 Ends Options** window – this time **Routing Options** has been selected.

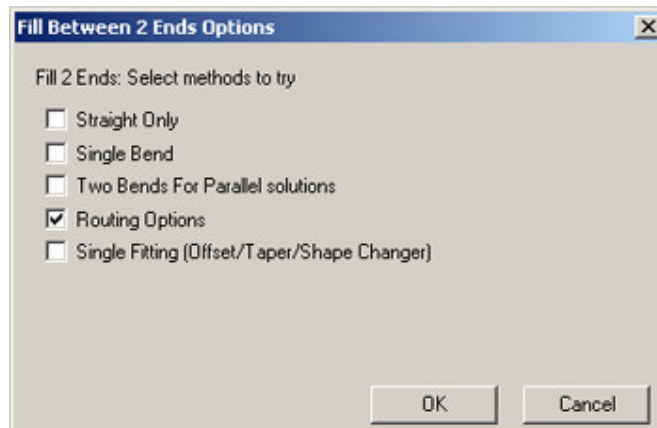

As previously, the user should select the items he wishes to be joined..

**Click** on the connector end of the **first item** to be joined

**Click** on the connector end of the **second item** to be joined

once again, the command line lists the possible options.



Type **N** followed by the **Enter** key to scroll through the available options. Each option is outlined within model space in real time as a preview of the resulting selection.

3D Routing options provide a quick and easy way to join services on different levels and offsets.

Routing calculates the **most efficient options** for selection. As you can see in the **Round** example there is a three-bend solution (which would, of course, also apply to **Pipework**), where this would not be possible with **Rectangular** or **Electrical** (minimum four bend solutions).

In this particular scenario the user is given **two possible options** from which to select:

### Rectangular Option 1

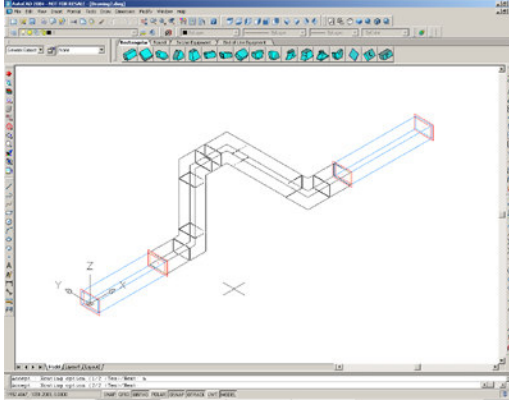

### Rectangular Option 2

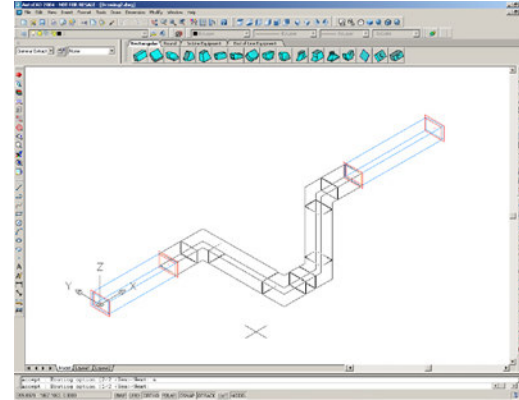

### Round Option 1

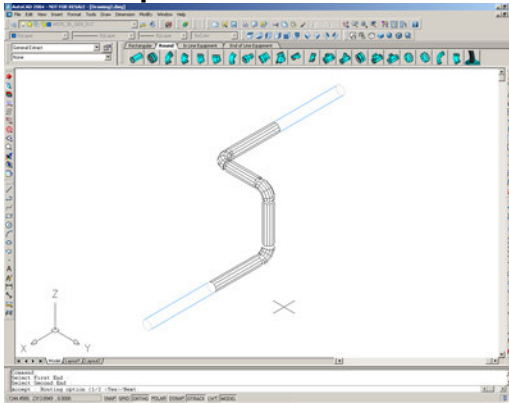

### Round Option 2

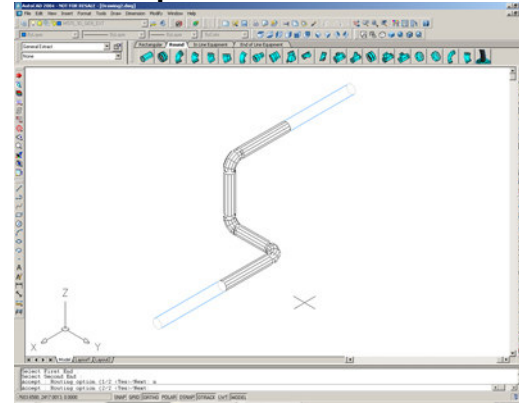

### Electrical Option 1

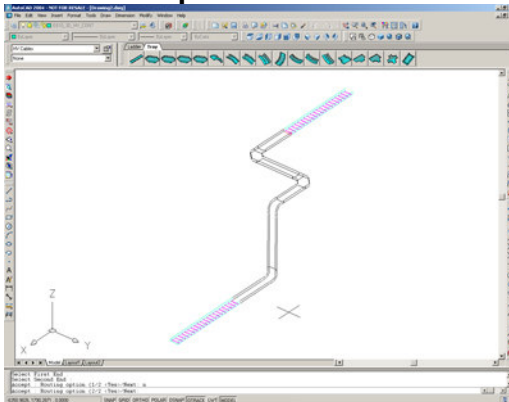

### Electrical Option 2

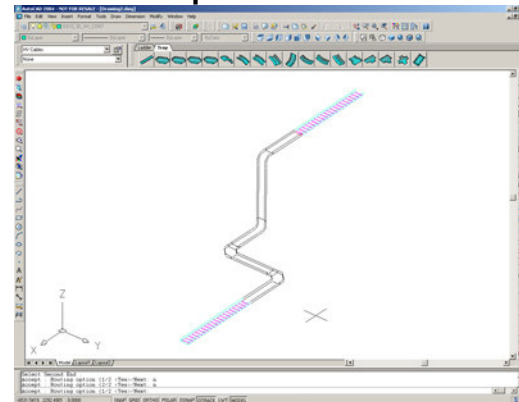

### Additional Information

There is, however, one option which is fixed.

If the first and second connectors are different sizes then a Taper / Transition will be used.

As mentioned previously there is the option to **Exclude Items** from the Fill routine - Fill looks at all the Items within the selected Service to give the user the greatest number of possible options. As this is the case depending on the Service selected Excluding Items from the Fill routine will be necessary to stop undesired results.